

NEMA

Northeastern Midget Association

2015

Rulebook

Table of Contents

PREFACE	Page 6
Article I – NEMA Rulebook	Page 7
1.1 Effective Date.	
1.2 Amendment.	
1.3 INTERPRETATION and APPLICATION.	
1.4 FINALITY	
1.5 Extraordinary Circumstances.	
1.6 Communication/Temporary rules.	
Article II – Membership	Page 8
2.1 Eligibility.	
2.2 Suspension/ Termination.	
2.3 Expiration.	
2.4 Independent Contractor.	
2.5 Officers.	
2.6 Contest Board.	
2.7 NEMA Officials.	
2.8 Voting Qualifications.	
2.9 A Technical Committee.	
2.10 General Meetings.	
2.11 Release of Name.	
Article III – Safety	Page 12
3.1 Ambulance, and Fire Protection.	
3.2 Assumption of Risk	
3.3 Notification of Injury	
3.4 NEMA Safety Committee	
Article IV – NEMA Competition	Page 13
4.1 NEMA Competition Event.	
4.2 Eligibility & temporary licensing	
4.3 Substance Abuse.	
4.4 Conduct	
4.5 Personal Appearance.	
4.6 Car Inspections	
4.7 Un-scheduled Practice.	
Article V – Car Identification	Page 14
5.1 Upright chassis.	
2014 NEMA RULEBOOK 1-1-15 REV	Page 2

- 5.2 Numbering
- 5.3 Duplicate Numbers
- 5.4 Required Decals
- 5.5 Transponders

Article VI – Driver Requirements

Page 15

- 6.1 Physical Examination.
- 6.2 Physical Examination @ Track
- 6.3 Divers Gear Required
- 6.5 In car @ Push off.
- 6.6 NOVICE Driver
 - a. Definition
 - b. Starting Positions
- 6.7 Mandatory Drivers Meeting.
- 6.8 Radio Communication System

Article VII – Technical Requirements

Page 17

- 7.1 Mechanical Condition and Appearance.
- 7.2 Seasonal Tech.
- 7.3 Fire Extinguisher Required.
- 7.4 Visual Inspection, Recommended Parts
- 7.5 Roll Cage, Nerf & Bumper Requirements.
- 7.6 Car Weights.
- 7.7 Approval of New Engines.
- 7.8 Safety Belt & Neck Restraint Required.
- 7.9 Cubic Inch Limits
- 7.10 Engine Rule Changes.
- 7.11 Firewall Construction.
- 7.12 Seat Construction.
- 7.13 Fuel Cell.
- 7.14 Wheelbase.
- 7.15 Maximum Width.
- 7.16 Maximum Wheel Size, Exceptions.
- 7.18 a. Rear End Offset.
- 7.19 Front and Rear Axle Material.
- 7.20 Open Drive Shafts Prohibited.
- 7.21 Water Cooled Engines Layover.
- 7.22 Four Wheel Hydraulic Brakes Required.
- 7.23 Declutching Device
- 7.24 Fuel Shut Off Valve.
- 7.25 Quick-Release Steering Wheel Hub.
- 7.26 Engine Cut-Off Switch.
- 7.27 Throttle Linkage Return Springs.
- 7.28 Exhaust.
- 7.29 Wings or Airfoils Required.
- 7.30 Maximum Wing Size.
- 7.31 Under Pans Required.

- 7.32 Fuel Additive Ban.
- 7.33 Engines Coolants Allowed.
- 7.34 Catch Tank Required.
- 7.35 Rear View Mirrors Banned.
- 7.36 Radiators.
- 7.37 Computers, Cockpit Adjuster & Esslinger ST.
- 7.38 (Reserved)
- 7.39 On-Board Fire Extinguishers.
- 7.40 Rolls Over Protocol.
- 7.41 Airfoils, Wings, Spoilers Not Permitted.
- 7.42 Welded Titanium Suspension Parts Prohibited.
- 7.43 Sail Panels Allowed.
- 7.44 Cockpit adjustments
- 7.45 Shocks
- 7.46 Vehicles deemed Not In the “Spirit” Of Rulebook

Article VIII – Flags

Page 28

- 8.1 Use Of Flags Outlined.
- 8.2 GREEN Flag.
- 8.3 PASSING Flag.
- 8.4 BLACK Flag.
- 8.5 YELLOW Flag.
- 8.6 RED Flag.
- 8.7 WHITE Flag.
- 8.8 CHECKERED Flag.

Article IX – Competition Starts

Page 29

- 9.1 All Starts Double File.
- 9.2 Push Off Procedure.
- 9.2 a. Push Off Procedure.
- 9.3 Dropping Out Of Line.
- 9.4 Passing
- 9.5 Qualifying Events.
- 9.6 Feature Events
- 9.7 Delays.
- 9.8 Scuffing Tires.
- 9.9 Provisional Starting Spots.

Article X – Competition Restarts

Page 30

- 10.1 First Lap Incidents.
- 10.2 All re-starts
- 10.3 Re-Start Procedure
- 10.4 Race Completed @75% Distance.
- 10.5 Immediate Removal from Track after Spinout.
- 10.6 Maximum Allowed Spinouts.
- 10.7 Red Flag Repairs Allowed.
- 10.8 Stopped On Track.

- 10.9 Maximum Push Distance.
- 10.10 Hot Laps.
- 10.11 Refueling

Article XI – Points

Page 31

- 11.1 Points Fund.
- 11.2 Points for,
 - a. Championship
 - b. Bonus
 - c. Handicap
- 11.3 Equal CHAMPIONSHIP POINTS, Owners and Drivers.
- 11.4 BONUS Points.
- 11.5 CHAMPIONSHIP POINT SCHEDULE.
- 11.6 HANDICAP Points.
- 11.7 Handicap Registration.
- 11.8 Heat Race Points.
- 11.9 Match or Special Races.
- 11.10 Rain Outs.
- 11.11 Pay-off.
- 11.12 Car Qualifies Only.
- 11.13 Qualifying Driver to Start Race W/O Penalty.
- 11.14 Co-sanctioned Events.
- 11.15 Appearance Awards.
- 11.16 Advancing Lites Winner to NEMA Feature

Article XII – Penalty Guidelines

Page 36

- 12.1 Procedure.
- 12.2 Violation of NEMA Rules.
- 12.3 Fines.

Article XIII - Protests

Page 38

- 13.1 Technical Protests.
- 13.2 Other Protests.
- 13.3 Non-Protestable Matters.
- 13.4 Protest Review.

Article XIV – Appeals

Page 38

- 14.1 Appeals.
- 14.2 Request, In Writing.

Lites Addendum

Page 39

Appendix A

Page 42

PREFACE

The corporate name of the organization is the Northeastern Midget Association, Incorporated. It is a not-for-profit corporation organized under the laws of the state of Massachusetts. It will also be known as the Northeastern Midget Racing Association; N.E.M.A.; NEMA; or N.E.M.R.A. The NEMA “Lites”© division is a subdivision of NEMA.

Any reference in this book to any of the foregoing or to the club will mean Northeastern Midget Association Inc., as an organization, not as any one person or an officer. This organization is formed for the mutual benefit and welfare of midget racing car owners and drivers, the promotion of midget racecar development and racing, and the betterment of the sport. The organization is primarily in business as a not-for-profit sanctioning body for midget car races. NEMA may also be promoters if the situation warrants, but promotion is not its primary function. NEMA may co-sanction racing events with other cooperating racing or entertainment organizations. NEMA and NEMA Lites Teams will only compete in races and competition events sanctioned by or approved by the NEMA Board. At the present time NEMA recognizes and is in agreement with ARDC and USAC which allows a member to participate in events only outside the New England Area.

The rules and/or regulations set forth herein are designed to provide for the orderly conduct of NEMA competition events and to establish minimum acceptable requirements for such events. These rules shall govern the conditions of all events, and, by participating in these events, all participants agree to comply with these rules. NO EXPRESSED OR IMPLIED WARRANTY OF SAFETY SHALL RESULT FROM PUBLICATIONS OF OR COMPLIANCE WITH THESE RULES AND/OR REGULATIONS. They are intended as a guide for the conduct of the sport and are in no way a guarantee against injury or death to a participant, spectator, or official. The Officers and Contest Board shall be empowered to permit minor deviation from any of the specifications herein or impose any further restrictions that in their opinion do not alter the minimum acceptable requirement. **NO EXPRESSED OR IMPLIED WARRANTY OF SAFETY SHALL RESULT FROM SUCH ALTERATION OF SPECIFICATIONS.**

ARTICLE I

NEMA RULEBOOK

1.1 Effective Date. The NEMA Rulebook and any amendments thereto, shall become effective immediately upon a majority vote of the General Membership or Officers and Contest Board and shall apply to all NEMA sanctioned events.

1.2 Amendment. The NEMA rulebook may be amended only by Officers and Contest Board duly elected by the membership.

1.3 INTERPRETATION and APPLICATION. In the event that there is a dispute concerning the interpretation and application of the NEMA Rulebook, the interpretation and application of such rule by the NEMA Officials shall prevail. Notwithstanding the forgoing, in accordance with Article XIV, the Officers and Contest Board shall have the authority to review any interpretations by the Officials.

1.4 FINALITY. The interpretation and application by the NEMA officials of the NEMA Rulebook shall be final and non-appealable, except as provided in Article XIV herein. In consideration of receiving the benefits of NEMA membership and in an effort to promote the orderly conduct of race events, **ABSENT BAD FAITH ON THE PART OF ANY NEMA OFFICIAL, ALL MEMBERS AGREE THAT ANY INTERPRETATION OR APPLICATION OF THE NEMA RULEBOOK BY A NEMA OFFICIAL IS NON-LITIGABLE, AND FURTHER AGREE THAT THEY WILL NOT INITIATE OR MAINTAIN ANY LEGAL ACTION AGAINST NEMA OR ITS OFFICIALS, CONTEST BOARD MEMBERS OR AGENTS, TO REVERSE OR MODIFY SUCH INTERPRETATIONS OR APPLICATIONS OR TO RECOVER MONETARY DAMAGES OR ANY OTHER EQUITABLE RELIEF. ANY MEMBER WHO INITIATES SUCH AN ACTION IN VIOLATION OF THIS SECTION SHALL BE RESPONSIBLE FOR ALL COSTS, INCLUDING REASONABLE ATTORNEY'S FEES, INCURRED BY NEMA IN DEFENSE OF THAT ACTION. NOT WITHSTANDING THE FORGOING, IN THE EVENT ANY MEMBER BRINGS SUCH ACTION AGAINST NEMA OR ITS OFFICIALS, ALL MEMBERS HEREBY WAIVE ANY RIGHT TO A TRIAL BY JURY IN SUCH ACTION AND ACCEPT THAT THE MATTER WILL BE TRIED BEFORE A JUDGE OF COMPETENT JURISDICTION.**

1.5 Extraordinary Circumstances. In the event of circumstances that are unforeseen or extraordinary are presented to the NEMA Officials, and strict application of the NEMA Rulebook may not allow them to adequately redress the situation, the NEMA Officials may make such determination as they deem necessary

to resolve the situation, even if inconsistent with the NEMA Rulebook. Such emergency action by the NEMA officials is reviewable by the Officers and Contest Board in accordance with article XIV.

1.6 Communication/Temporary Rules. In the event a particular racing event requires special rulemaking by NEMA Officials, and such rules shall apply to the conduct of the NEMA Competition Event, all competitors shall be notified of the special rules prior to that racing event. Any changes to the current NEMA rulebook, or any rule put in place during the year that the Officers and contest board have changed or altered in any way, car owners will be notified five (5) days before those rules are put in place.

ARTICLE II

MEMBERSHIP

2.1 Eligibility. Any interested individual is eligible for membership. Those individuals under the age of 16 will be eligible for associate membership only, except those individuals who are 14 years of age (or older) and are NEMA Lite drivers. Those Associate members under the age of 16 have all of the rights and privileges of a regular member with the exception of voting privileges. All persons under the age of 18 years age must have proper parental approval from both mother and father (or all legal guardians) to become members. All applicants must complete and sign a membership application, pay the appropriate membership fee, complete a parental consent form if applicable and agree to be subject to the rules and regulations of NEMA in force at the time of joining and all rules or regulations that may be enacted by NEMA thereafter. Any individual who engages in conduct detrimental to NEMA or midget auto racing in general, whether or not during a NEMA Competition Event, and whether or not a member of NEMA at the time, may have his application rejected by NEMA. In addition, absent bad faith, NEMA expressly reserves the right to reject the application for membership of any potential member in the best interests of NEMA. Any such rejection may be appealed to the Officers and Contest Board in accordance with Article XIV. Membership applications may be obtained from the Secretary or from the NEMA web site, and must be completed, signed, and returned to the Secretary with the required membership fee. Acceptance by the secretary does not constitute an acceptance of the membership application. All applicants will be notified in writing of the disposition of their membership application. Accepted members will receive their membership card. Car owners may register additional cars for a Twenty Five dollar (\$25.00) fee each, however these registrations will not entitle said owners to additional voting privileges.

2.2 Suspension/Termination. NEMA may suspend or terminate any member for a prescribed period, or

indefinitely, if it determines that such action is in the best interest of NEMA and the promotion of midget auto racing. Similarly, any member may voluntarily terminate their membership by notifying the Secretary in writing of their intention to terminate their membership and must return their membership card. Any member suspended or terminated involuntarily may appeal the decision to the Officers and Contest Board pursuant to Article XIV. Any member that competes in an unsanctioned Pavement Midget event the same day as a scheduled NEMA event will lose their handicap.

2.3 Expiration. All memberships shall expire on the last day of the calendar year for which they were issued. A new membership application must be completed, signed, and submitted to the Secretary for each racing season.

2.4 Independent Contractor. All NEMA members acting in any capacity shall be considered independent contractors and shall not be employees, servants, or agents of or for NEMA. It shall be each member's obligation to supply any tools or other equipment needed to function in their capacity as members of NEMA. All members shall be responsible for the actions of their employees and/or agents. Members assume and take all responsibility for all charges, premiums, and taxes, if any, that may be payable on any funds that they receive as a result of his/her racing activities, including, without limiting to, social security taxes, unemployment taxes, compensation insurance, income taxes and withholding taxes. Upon arrival at a NEMA Competition Event, all independent contractors must be signed in with the Secretary or designated person prior to the start of each event.

2.5 Officers. The Officers of NEMA shall consist of a President, 1st Vice President, and 2nd Vice-President (if necessary), Secretary and a Treasurer. In order to be eligible to hold one of the above mentioned offices, an individual must be a current member of NEMA and have been an active member in good standing with NEMA for the previous year.

The President will preside at all meetings and countersign with the Treasurer, any and all drafts or warrants necessary in the operation of the association. He will sign together with the Secretary or Treasurer on contracts or agreements committing the association to indebtedness. He will generally manage the business affairs of the association.

The Vice-President will assist the President in any areas he designates and take over the duties of President in his absence at any meetings and/or racing events.

The Secretary will transcribe the minutes of each and every meeting (both general and Contest Board), issue such correspondence as may be directed by the President or the Officers and Contest Board, keep an up to date list of all members, and their date of paid membership, be responsible for keeping an

accurate and up to date record of point standings of cars and drivers, make point standings available and open to inspection by members at any reasonable time, and submit printed and complete "Reports of the Secretary" relating to the accounts and business of NEMA at the general meeting.

The Treasurer will hold all funds in a bank for the benefit of this organization, make or sign warrants or drafts only when the President co-signs with him, keep a regular set of books and account for all monies received and spent by the organization, make the books available and open for inspection at any reasonable time, and submit printed and complete "Report of the Treasurer" relating to the accounts and business of NEMA at the general meeting.

2.6 Officers and Contest Board. In order to be eligible to hold a position as Officer or Contest Board member, an individual must be a current NEMA member and been an active member in good standing during the previous year. An Officer or Contest Board member will be dropped from the board if he/she misses two (2) unexcused meetings. The remainder of the board will elect a replacement. If a Contest Board member leaves the board during their elected term; they are ineligible for election for the next term. The Officers and Contest Board will consist of six (6) elected members and up to 5 additional members. The contest Board may:

- a. Protect the interest of the members as its primary function.
- b. Enact such rules and regulations as they see fit and enforce same.
- c. Be responsible for the enforcement of all matters pertaining to competition.
- d. Be the Officers and Contest Board in all matters pertaining to competition.

The six elected members of the Contest Board may elect a chairman from their members. The Officers and Contest Board may hire a Business Agent. There will be no restrictions as to whether he/she is a club member or has other office capacities with the club. His remuneration and specific duties will be determined by the Officers and Contest Board. These duties are to include, but not be limited to, procurement of racing dates and their financial arrangements. The Business Agent may attend Executive Board meetings, but will not have a vote in its operations. Handicapper, Pit steward, Starter, Scorer and assistants as necessary, will be furnished by NEMA and hired by the Business Agent or Officers and Contest Board. Other personnel may be hired or appointed by the Officers and Contest Board, (such as a LITE car representative), as deem necessary for the proper operation of NEMA. Any such additional personnel will have no voice in the operation of the club, although their attendance at the meetings of the NEMA Officials may be desirable. All working track personnel who receive compensation for their duties must be NEMA members. Any eligible member may submit, to the Secretary, their name for nomination to

an office. These nominees will be presented at the general meeting for the election of officers. All officers and board members must attend 50% of the NEMA sanctioned events during the season for which they were elected.

2.7 NEMA Officials. Together, the elected Officers and members of the Contest Board, as well as any agents hired by the above mentioned, shall be the NEMA Officials. Formulation of rules of conduct and membership rules shall be within the sole discretion of the NEMA Officials. A majority of NEMA Officials must be present to enact a rule and such enactment must be by a majority vote. The membership of NEMA shall be informed of the decision of the NEMA Officials either at the general meeting or by e-mail.

2.8 Voting Qualifications. In order to be eligible to vote, an individual must be a current NEMA member in good standing (suspended members are ineligible to vote), have paid the requisite membership fee at the time of voting and must be 16 years of age or older. All such members are qualified to vote in the election of Officers and members of the Officers and Contest Board.

2.9 Technical Committee. A Technical Committee will be comprised of members from the Officers and Contest Board. All proposals regarding car specifications shall be submitted to the Technical Committee. All decisions on technical proposals will be delayed until the Board for the forthcoming season has been elected and convenes a Board meeting for this purpose. The Officers and Contest Board shall then research and investigate all proposals and render a decision to the membership by e-mail. The decision of the Committee shall require a 2/3-majority vote for acceptance, and shall be final. Car owners may overrule any decision of the Officers and Contest Board by presenting a petition signed by ten (10) eligible car owners to the Officers and Contest Board requesting reversal. This petition must be received by the Secretary within fifteen (15) days of the Member Notification of Rule Changes. Ballots will then be mailed to all eligible car owners who will indicate their vote by returning their ballot via U.S. mail to the Secretary. A 51% vote will overturn the Officers and Contest Board decision. For voting purposes, an eligible car owner will be he/she who has participated in 50% of the previous season's races.

2.10 General Meetings. There shall be a general membership meeting each year to be held within thirty (30) days of the last race of the season. There shall be a second general membership meeting each year to be held in December for the purpose of opening up the rules for amendments and for the addition of new rules. All proposals by the membership for inclusion at this general meeting agenda must be received by the Secretary no later than thirty (30) days prior to this scheduled general meeting. All proposed rule change must also be submitted to the Secretary within the same time frame. All proposed agenda items or rule changes not received by the Secretary within the time allotted above, shall not be included on the general

meeting agenda and must be submitted within the appropriate time frame for inclusion on the next general meeting agenda. An agenda will be mailed or e-mailed to all members fifteen (15) days prior to the scheduled general meeting date. A Third general meeting will be held not less than Thirty (30) days or more than Forty-Five (45) days after the December meeting. To call an additional general meeting, a petition must be presented to the President signed by ten (10) members in good standing. The petition will state the reason for calling the meeting. The meeting will be confined to the subject designated in the petition.

2.11 Proxy Voting. Proxy voting (voting for another member) under any circumstances will not be allowed.

2.12 Release of Name. In consideration of the acceptance of a membership application by NEMA and any prize money that may be won by the member during his membership, all members agree and consent that NEMA may use their names, pictures, likenesses or performances in any way, in any medium, in order to promote or advertise NEMA Competition Events, including, but not limited to commercial sales and projects. Members agree to relinquish all rights hereto for such purposes.

ARTICLE III

SAFETY

3.1 NEMA will not compete on any track unless there is adequate fire protection equipment, at least one ambulance, properly equipped, and with trained medical personnel in attendance. All NEMA drivers and on track Officials must participate in the insurance program specified by NEMA. Affected members will be responsible for payment of all applicable premiums.

3.2 All members acknowledge that automobile racing is an inherently dangerous sport and assume any and all risks with participating in NEMA events and further agree to notify their family members of their participation in NEMA events. While NEMA, its officers, agents, members, and business associates attempt, through enforcement of these rules, to reduce that risk, it cannot be completely eliminated. Because NEMA does not promote its own racing events, it has no control over the facilities at which NEMA races. Therefore, it will be the responsibility of NEMA, the promoters, and the members to share the responsibility for safety at the racetracks. The promoters are ultimately responsible for providing all required safety equipment and personnel and for maintaining the racing facility in such a way as to reasonably assure the safety of all NEMA members at that facility. NEMA and NEMA Officials shall

inform any promoter of any deficiency in safety equipment which it discovers or has been brought to its attention, but cannot insure the adequacy of the safety measures taken at a given racing facility. Ultimately, all members are responsible for inspecting the facility for proper safety procedures and reporting any apparent deficiencies to NEMA or the promoter. In addition, car owner members are responsible for the safety of their race cars, and agree that neither NEMA nor the promoter shall be responsible for any occurrence as a result of the lack of the proper safety equipment on any member's racecar.

3.3 At the earliest practical time, any member injured at a racing facility during a NEMA Competition Event must notify a NEMA Official prior to leaving the facility.

3.4 NEMA will have a Safety Committee in place to monitor and oversee all teams competing in NEMA and NEMA Lites competition. The Safety Committee will address all safety matters pertaining to, inspecting all driver personal protective equipment, (PPE), ensuring they are up to date and in good condition, along with the safety condition of all cars. The Safety Committee will be the liaison between the club and track safety crews, including pit / pit road safety. The Safety Committee's duties and responsibilities will be but are not limited to

- 1) Periodic safety meetings with the drivers at the driver meetings to address all safety concerns.
- 2) Discuss new technology, new suggestions; assist drivers with assessing condition and expiration date of belts, etc., possibly start a PPE exchange / hand me down program for used but effect equipment. Discuss the location of safety belts and their anchors.
- 3) Evaluation of Car safety; seat condition / mounting, cockpit safety; padding, sharp objects, fuel / oil line location.
- 4) Meet with tracks safety / first responders to insure all are familiar with the layout of the midget; fuel shut off, fuel line location, oil tank and oil line location. Insure ALL are on the same page when responding to a crash and / or roll over. (to right the car, remove the wing or not, etc.)
- 5) Pit safety with regards to fueling the car, jacking the, jack stands, pushing the car, busy pit road safety.

ARTICLE IV

NEMA COMPETITION

4.1 A NEMA Competition Event is a racing event which NEMA has agreed to sanction at a particular racing facility and has executed a NEMA Competition Agreement.

4.2 Only current members in good standing may compete in NEMA Competition Events. Any current

member of an established racing organization will be allowed to obtain a "temporary racing membership" to compete in a NEMA Competition Event (non co-sanctioned) provided he/she shows their current club membership I.D. and pays a fifty dollar (\$50) non-refundable fee for each such Competition Event. Such individual agree to abide by the rules and regulations of NEMA and will be required to sign a NEMA release form. Temporary permits are limited to two (2) per car or driver per season.

4.3 The use of alcoholic beverages, narcotics or controlled substances are prohibited in the pit area during the course of any NEMA Competition Event. All members agree to abide by NEMA's Substance Abuse Policy, incorporated herein.

4.4 Because NEMA does not promote its own racing events, all members agree to abide by the rules and regulations of any racing facility at which a NEMA Competition Event is held.

Member car owners shall be responsible for all who have pit passes on their car, and will be responsible for insuring that the conduct of those persons is in accordance with NEMA rules and regulations.

4.5 All Drivers, owners and pit crew members must present a neat and clean appearance. UNIFORMS ARE ENCOURAGED.

4.6 In accordance with rule 7.2, all cars competing in a NEMA Competition Event are subject to inspection by NEMA for compliance with the rules and regulations of NEMA. All decisions of NEMA reached as a result of such an inspection shall not be appealable, except to the extent permitted by Article XIV.

4.7 Un-scheduled practice at any race facility within six (6) days prior to a NEMA Competition Event at that facility is prohibited. If a competitor violates this rule, they will be allowed to compete at the event, however, they will start last in the feature, scored one(1) lap down at start of feature, no championship points will be awarded and will be credited a win for handicapping purposes.

ARTICLE V

CAR IDENTIFICATION

5.1 For identification purposes an upright chassis is one where the driver straddles the drive shaft when driving. Only upright chassis are eligible for competition.

5.2 Cars will be required to use only the number assigned at the time of registration. The number shall be applied to both sides of the car to be easily identified at a reasonable distance. Numbers must also be displayed on the top of the wing. Top numbers must be at least 18" in height.

5.3 In case of duplication of numbers on cars at the track, the car that has been assigned the number by the

Secretary is the car that is entitled to use the number. Continuity and Seniority exists. Preference of numbers is then given on a first, come first serve, basis. Disputes over car numbers will be decided by the Officers and Contest Board. The car that is not entitled to the number must have a new number on the car in a manner such as to satisfy the Officers and Contest Board.

5.4 All NEMA midget cars may be required to display the NEMA decal and any other major point-fund sponsor decals on the body area designated by the Officers and Contest Board. It may be also required to display other temporary sponsor's decals of the day or series.

5.5 All cars owners are required to have their own AMB transponder and charging base at all times. NEMA Lites cars will be subject to a “breakout penalty” if the car is found to not have a transponder affixed at any time.

ARTICLE VI

DRIVER REQUIREMENTS

6.1 All drivers must submit to a physical examination and will provide all necessary documentation to NEMA before being allowed to compete. Subsequent physical examinations are required each year, the exception being a Department of Transportation, (DOT) certification, which has two-year validity. The examination is to be at the applicant's expense. No one may drive, if in the opinion of the examining doctor they have an affliction that may slow down their reflexes and/or make them a menace on the track. Drivers will submit the completed physical form with their membership application to the Secretary. The standard Physical Examination Form provided by a doctor will be acceptable. Any driver failing to provide proof of a valid physical examination to the Secretary PRIOR to a NEMA Competition Event shall not be allowed to compete in a NEMA Competition Event. It shall be the responsibility of the driver to confirm receipt of the physical.

6.2 A driver can at any time requested by a NEMA Official, be required to undergo a physical examination by the tracks medical personnel or EMT to determine if he/she is over fatigued or under the influence or impaired by drugs or alcohol. The decision of the medical personnel available is final and without recourse for that NEMA Competition Event.

6.3 All drivers are required to wear suitable, double layer, fire-retardant, long-sleeved uniforms when driving. The Officers and Contest Board may approve uniforms. Arm restraints are required. Nomex hoods and underwear are encouraged. Gloves, shoes, socks, etc. are required. All drivers participating in

any NEMA Competition Event must wear a head and neck restraint, such as a Hans or Hybrid device, with a minimum rating of SFI Foundation Spec. 38.1. A neck collar is not considered a head restraint. The driver will use the belts, harness and arm restraints at all times the car is driven.

6.4 All participating drivers must wear safety helmets designed specifically for auto racing that meet or exceed the 2000 or 2005 Snell Foundation 31.1 specifications and labeled as such. The Officers and Contest Board will order questionable helmets replaced.

6.5 While on the racetrack, a driver will be in his/her car unless actively pushing it in preparation of being pushed-off for the start of warm-ups, qualifying or the main event. Any driver who exits their car after the green flag has been given will not be allowed to restart that race. Drivers that exit their cars, whether it's for an emergency or if instructed to do so by a track or NEMA Official, will do so in a safe and timely manner. Once out of the car drivers will get into a safety vehicle unless they are instructed to get into an ambulance

6.6 A NOVICE driver is one who has never or has seldom driven a midget race car in competition:

a. Drivers fourteen (14) to (17) may enter a NEMA Lite Competition Event provided they provide to NEMA in advance of the NEMA Competition Event an appropriate release of liability in the favor of NEMA, signed and notarized by both parents or parental guardian(s), provide proof of medical insurance and are qualified to compete in the sanctioning track's events pursuant to state and local rules and regulations. A committee shall be established to oversee minor drivers and evaluate their performance.

b. Drivers seventeen (17) years old may enter a NEMA Competition Event provided they provide to NEMA in advance of the NEMA Competition Event an appropriate release of liability in the favor of NEMA, signed and notarized by both parents or parental guardian(s), provide proof of medical insurance and are qualified to compete in the sanctioning track's events pursuant to state and local rules and regulations. A committee shall be established to oversee minor drivers and evaluate their performance.

(An age variance for drivers at least 15 years of age may be allowed for NEMA competition based on proven success and prior experience in the NEMA Lite series. This variance must be approved by the NEMA Board.)

c. At the discretion of the Race Director, Handicapper and/or the Officers and Contest Board, a novice may be required to start at the rear of the field for at least three (3) races. The Officers and Contest Board will decide by the end of the three events as to whether the novice will have to continue to drive in the rear for more experience, or will drive from their handicapped position. The novice will be instructed by the starter as to the primary rules of midget racing before being allowed to compete.

6.7 There will be a mandatory meeting of all drivers competing in a NEMA Competition Event,

approximately fifteen (15) minutes prior to the running of the Track's first heat race of the program. Exact time and place for such meetings will be determined by NEMA officials during the warm-up session. It will be the responsibility of each individual driver to attend said meetings.

6.8 All drivers must utilize the one-way radio communication system provided to them by their owners, for communication from a selected NEMA Official only. Radios are mandatory at all times, even during practice.

ARTICLE VII

TECHNICAL REQUIREMENTS

7.1 All cars must arrive at the track in good mechanical condition and be in good appearance.

Any car, which in the opinion of the Officers and Contest Board and/or an authorized representative, that is not in good condition or deemed not to be in the spirit of the rulebook, will not be allowed to run. The Officers and Contest Board will give adequate reasons for this decision.

7.2 At the discretion of the Officers and Contest Board or its representative, cars will be required to pass a technical inspection by the Officers and Contest Board or authorized representative prior to the first race. Any car registered during the racing season will be required to be inspected before it will be allowed to be raced. Any car at any time that shows either non-conforming applications of NEMA rules or unsafe workmanship shall be barred from competition until such faults are corrected. The decision of the board is final. Car owners are solely responsible for the building and maintaining of a safe racecar. At the conclusion of every NEMA Competition Event, all cars finishing first, second, and third (and potentially others) must report directly to a technical inspection. The place for said inspection will be announced at the mandatory drivers meeting required by Rule 6.7. It will be the responsibility of the car owner and the driver to ensure that the car is presented for inspection immediately after the conclusion of the feature event. Non-compliance will result in forfeiture of the purse earned. These inspections, under certain circumstances, may be waived by the NEMA Officials.

7.3 Each registered car is required to have in their individual pit area, a readily accessible, working fire extinguisher, with a minimum 5 lb. capacity of dry chemical or CO2 recommended.

7.4 NEMA strongly recommends that the following parts have non-destructive visual inspection by magnetic particle dye penetrant examination. These tests should indicate that the individual parts are in satisfactory condition for their intended use. Use of a tested part indicates that the owner is responsible for the use. If tested, owners should retain copies of the testing certificates.

- a. Steering box including steering wheel hub
- b. Spindles, hubs and steering arms
- c. Kingpins or ball joints
- d. All heim ends or tie rod ends in front suspension and steering
- e. Front axle and/of suspension control arms

7.5 A roll cage manufactured before 1/1/2000 is required and must be made of an approved design. For roll cages constructed after 1/1/2000, the cage shall be of quality material (SAE4130) of a minimum 1 1/4 inch diameter and .093 wall thicknesses. A roll cage manufactured after 1/1/2008 shall be of quality material (SAE 4130) of 1 3/8 inch diameter and .093 wall thickness. All cages must be constructed in such a way that the driver's helmet does not protrude in any manner through the top of the cage. Each car must have a front bumper, rear bumper, right side nerf bar and left side nerf bar. The bumper and nerf bars must be constructed of SAE4130 or equivalent tubing with a minimum O.D. of 3/4 inch and having a wall thickness of minimum .065 inch and a maximum wall thickness of .120 inch. No ballast is allowed in the bumper tubing, nerf tubing or chassis tubing. **Any ballast that is required must be securely fastened within the confines of the frame rails.**

7.6 Car weights (minus 1% scale error) will be as follows:

- a. 145-166 ci VW engine cars must weigh a minimum of 1025 lbs
- b. 174 c.i. VW engine cars must weigh a minimum of 1075 lbs.c. 166 c.i. and smaller in-line engine cars must weigh a minimum of 1100 lbs.
- d. 174 c.i. in-line engine cars must weigh a minimum of 1125 lbs.
- e. 161 c.i. SOHC, 2 valves per cylinder alloy block and cylinder head XT/Tall head Esslinger engine cars must weigh a minimum of 1150 lbs.
- f. 155 c.i. SOHC, 2 valves per cylinder alloy block and cylinder head Esslinger engine cars and 161 c.i. SOHC 2 valve per cylinder
- g. Esslinger EST engine cars, must weigh a minimum of 1125 lbs.
- h. 145 c.i. DOHC, 4 valves per cylinder cars must weigh a minimum of 1100 lbs.
- i. 155 c.i. SOHC, 2 valves per cylinder alloy block and cylinder head Esslinger engine cars and 161 c.i. SOHC 2 valve per cylinder Esslinger ST/Short Deck Head engine cars, must weigh a minimum of 1100 lbs.
- j. All cars with engines allowed pursuant to Rule 7.9(m) must weigh a minimum of 1075 lbs.
- k. No car may have more than 60% left side weight (allowing 1% scale error) as it comes off the

track after the Feature Event.

Note: Cars utilizing titanium connecting rods must adhere to rule 7.9 r.

Note: Maximum weight for any car with engine, regardless of which engine, is 1425 lbs including the driver. Car weight may be determined on the NEMA scales *including* the driver, as the car comes off the track with gear immediately after the finish of the Feature Race.

7.7 Any engine or chassis not now running with NEMA shall be submitted to the Officers and Contest Board for evaluation before being allowed to compete.

7.8 A quick-release type safety belt is required. The belt is to be 3" nylon, securely attached to the frame of the car. All cars must also have an approved over-the-shoulder harness and a crotch (submarine) belt attached to the frame. All belts must be dated by the manufacturer and must be not more than 4 years old. All belts must also be labeled with SFI Foundation specification 16.1 or 16.5.

7.9 The Officers and Contest Board will have the right to measure engines for cubic inch limits at random with no protest fee. For the sake of measuring the engine for cubic inch limits, there will be an allowance of 2% of the total allowable cubic inches for a clean-up bore. Engine specifications are as follows:

- a. Double overhead cam engines--140 c.i.
- b. Single overhead cam engines--140 c.i.
- c. Single overhead cam engines (with cast iron head or block)--155 c.i.
- d. VW engines and VW type engines--174 c.i.
- e. SESCO pancake 4 cycle opposed engines--156 c.i.
- f. Any push rod, 4 cylinder, water-cooled in-line iron block with any head--185 c.i.
- g. Any push rod, 4 cylinder, water-cooled in-line iron block with a compatible iron head--195 c.i.
- h. Single overhead cam, 2 valves per cylinder alloy block and cylinder head, Esslinger Engines only--161 c.i.
- i. Push rod alloy component engines (Gaerte Chevy/Ford), head and/or block, water cooled--174 c.i.
- j. Cosworth Ford engines allowed--140 c.i.
- k. Mazda rotary type or Wankle engines not allowed
- l. Mopar engines allowed --166 c.i., wedged cylinder head. Hemi cylinder heads are not allowed.
- m. Any mass-produced engine installed on a production line in an automobile or a light truck falling within the following cubic inch displacements and crankshaft limitations with the cylinder head and block assembly that were mated at the time of production:

- (1) DOHC, 4 Valves per cylinder--145 c.i.

(2) SOHC, 2 Valves per cylinder--175 c.i.

(3) Push rod, 2 Valves per cylinder--195 c.i.

Aftermarket crankshafts will be allowed. After market connecting rods will be allowed.

Minimum weight limit: 900 lbs. All other car specs will conform to NEMA rules.

n. No two (2) cycle engines allowed.

o. No Scat VW type, water-cooled engines allowed.

p. No superchargers, turbochargers or forced induction (ie: Ram Air devices) allowed.

q. No reverse rotation engines allowed.

r. No titanium crankshafts allowed. As of January 2013, no new titanium connecting rods will be allowed. Existing engines and used engines purchased in the future with titanium rods will be allowed to continue to utilize them but must add 15 pounds to the minimum allowable weight for their chassis as is specified under rule 7.6.

s. Chevy V4: iron block, aluminum head--185 c.i.; aluminum block cut from Chevy V8--175 c.i.

t. Chevy V6: Iron Block, aluminum head--185 c.i.; aluminum block--175 c.i.

u. Crankcase venting into the exhaust will be allowed with the use of an anti-backfire valve in the venting line.

v. RPM limit shall be set by the rev limiter in the ignition box. The following limits have been set:

- Esslinger/SOHC engines - 9500 rpm

- DOHC engines - 9100 rpm

- Pushrod engines - (166ci) - 8400 rpm

- Pushrod engines (174ci) - 7800 rpm

The technical inspector may inspect compliance with this rule at any time during a NEMA Competition Event.

w. The downdraft style Esslinger head will not be allowed (e.g., exhaust exiting on lower left side)

x. Chevy 2.4 Ecotec is allowed in competition - NEMA competitors only (no Lites).

7.10 Any rule changes affecting a decrease in the cubic inch limits of an engine will require a one year waiting period before its effective date. Notwithstanding Rule 2.9 above, any changes in car specifications must be made prior to December 31 to be effective in the following season. Any clarifications made by the Officers and Contest Board are effective immediately.

7.11 A firewall between the driver and the engine compartment must be approved. The motor plate must be made of aluminum, magnesium or steel heavier than ¼ inch and may not be made from carbon fiber or other

composite materials.

7.12 Seat construction must be of aluminum or steel only, must be a full containment construction, as approved by NEMA officials. The Maximum allowable mounted seat angle will be $30^{\circ} + 1^{\circ}$ allowable for error. Measurements to determine the seat angle will use the following procedure which is taken from the Kirkey installation guide will be used. *The measurement will be taken approximately 8 inches up from the bottom of the seat.*

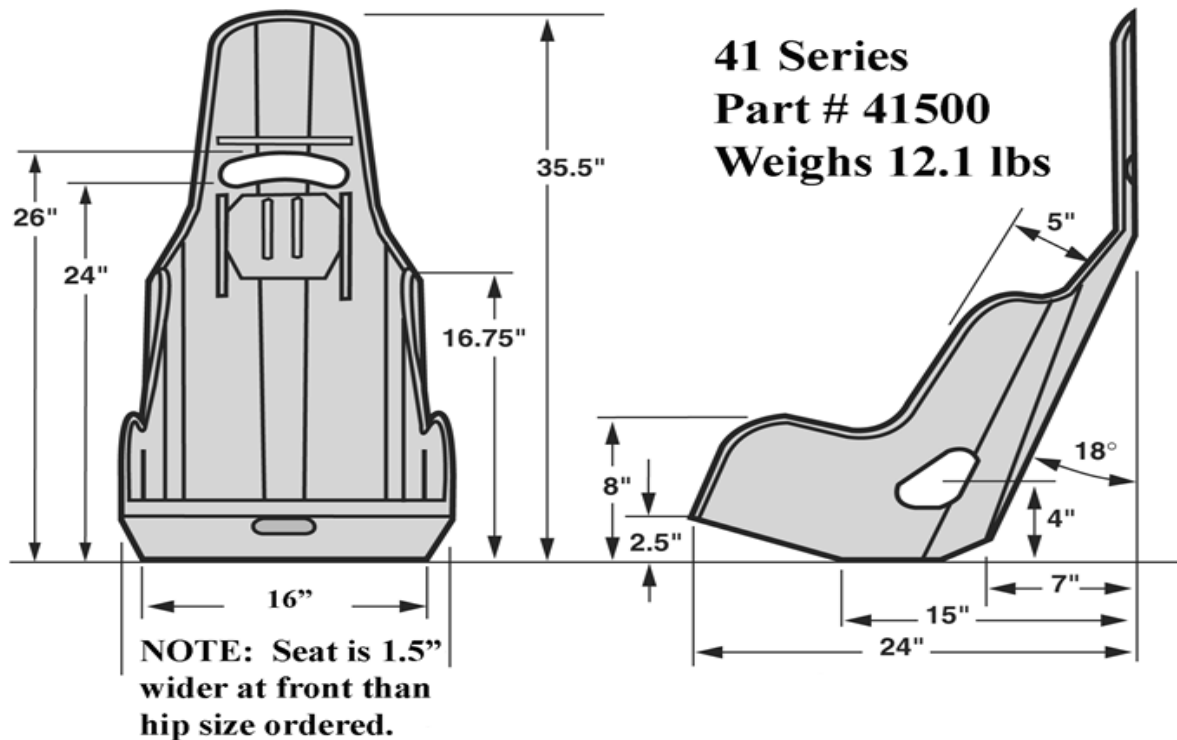

7.13 A conventional tail tank, fuel cell and the fuel contained must be carried no more than 1 inch offset to the centerline of the chassis and rear end and be located behind the driver. All cars must be equipped with a fuel cell and tail tank meeting the requirements of NEMA and SFI Specifications 28.2. Tail tanks must be 2 pieces maximum (plastic shell and bladder) and may not contain any aluminum, fiberglass, or carbon fiber. The bladder must be able to hold at least 18 gallons of fuel.

a. The conventional tail tank shape cannot be modified unless utilized to fit on a car built before 1998 and must be of one-piece construction. Spill plates, skirts or air deflectors may not be attached or used to aerodynamically enhance the tail tank.

b. Any tail tank surface that is modified to provide access for the fuel cell must, when covering this

opening, maintain the same shape as the original tank. Any cover used must be securely bolted around its entire perimeter.

- c. Fuel pumps may be installed in the tank, so long as there is a visible shut off switch accessible by safety crew members from the outside of the car.

7.14 Wheelbase shall not be less than 68" and shall not be greater than 76". Minimum ground clearance is one (1) inch at all times during a NEMA Competition Event, measured without the driver, after the Feature Event and with the weight jacker (if applicable) in a fully lowered position.

- a. In addition to wheel base there is a maximum allowable set back measured from back of the motor to the center of the rear end (43 in).

7.15 Maximum width front end and rear end is 65inches (65").

7.16 Maximum wheel size shall not exceed thirteen inches (13") in diameter, and eight (8") wide at the point where the tire bead sits on the wheel.

- a. All NEMA competition vehicles must run a 10" right rear wheel. In an attempt to economically assist certain vehicles, the Board will grant the ability to run a 12" wheel, at their discretion, based on the following criteria:

1. The competition vehicle must be in excess of 50 lbs of the minimum allowed weight as stated in the rulebook with 3 gallons of fuel.
2. The competition vehicle has displayed, in its previous outings, a need for the competitive benefit of a 12" wheel.

The Officers and Contest Board holds the right, at any time, to revoke this privilege based upon substantial changes to the above criteria. Footnote: Once approved for the wheel, it is not the Officers and Contest Board's intent to take it away.

- b. A tire not to exceed fifteen inches (15") at the bulge will be allowed.
- c. VW and VW type air cooled engine cars will be allowed a 10" right rear wheel and an 8" LR wheel on tracks a 1/3 mile or less and a 12" RR wheel and an 8" LR wheel on tracks greater than 1/3 mile.
- d. Iron block & head engines will be allowed a twelve-inch (12") right rear wheel and a ten-inch (10") left rear wheel.
- e. Direct mount or spindle mount wheels will not be allowed on the right front.
- f. NEMA Tire Rule: Each NEMA team will be allowed 3 new tires per event, per vehicle. Each Lites team will be allowed 2 new tires per event, per vehicle. Any team thought to be or found to be

acting outside of the intent of this rule will be penalized via loss of points, prize money, and/or suspension. No new or sticker tire shall be allowed for the Feature event. If a car chooses to use a new or sticker tire, the starting position is forfeited and the car must start at the rear of the field for the Feature event. If a vehicle is found to be violating the rule in warm-ups or heat races they will not be allowed to compete in that event.(warm up or heat race) NOTE; This rule may be modified for both NEMA and Lites by the race director if exigent circumstances present themselves that warrant the changes.

7.17 The crankshaft and center section centerline of the rear end can be offset no more than one inch (1") from the chassis centerline. The engine and the rear end center section must be moved in the same direction, with the crankshaft, driveshaft, and rear end lower shaft all being in a straight line. Only torque tube type drivelines, utilizing only one u-joint, will be allowed. The driveshaft must connect via an OEM (Winters, Halibrand) internal or external coupler into the center of the rear end housing, and run from that coupler into a female yoke connected to the crankshaft. The rear end gear assembly must be of conventional design with only one set of spur gears located behind the ring and pinion. Spherical driveshafts will be allowed.

7.18 Rear end offset of three inches (3") measured from the centerline of the rear end center section to the inside of the wheel flanges (bead seats), six inches (6") overall will be allowed. Clear access must be made available to measure offset--readily removable body panels or access holes at least three inches (3") in diameter must be present and provide straight-line access between the measuring points.

- a. Any in line push rod engine will be allowed 6.5" of rear offset.
- b. A front end offset of 11" overall will be allowed.

7.19 Front and rear axle material for axle construction is restricted to:

- a. The front axle must be made out of one, continuous piece of steel tubing from kingpin to kingpin – any deviation to this will be considered independent suspension (i.e., u-joint or split style front axles). Independent front suspension is not allowed. Manually adjustable caster/camber front axles are allowed.
- b. Rear axles must be steel or aluminum. No ultra-light rear axles will be allowed in NEMA Competition.

7.20 Use of open drive shafts is not allowed.

7.21 Water cooled engines cannot exceed forty-five (45) degrees layover, measured from the vertical centerline of the engine.

7.22 Four wheel hydraulic brakes are required to be in operating condition. Carbon fiber brake rotors are not allowed.

7.23 A declutching device (in and out of gear), must be present and in good working order.

7.24 A fuel shut off valve must be located in an easily visible and easily accessible by the driver.

A second fuel shut off valve, visually and readily accessible, is required to be installed in the fuel feed line between the tank and the engine in an area of open access on either side of the car.

7.25 An approved quick-release steering wheel hub mechanism is required.

7.26 A switch or cut-off button to stop the engine must be located in a place easily accessible to the driver.

7.27 Throttle linkage must have a minimum of two (2) return springs independently attached to the throttle linkage at separate locations.

7.28 Exhaust pipes must face away from the driver. All cars must be equipped with a working muffler.

Exhaust decibel level must not exceed 118 db as measured from the infield by NEMA equipment.

7.29 The use of wings or airfoils is required. Wings will be restricted to a single plane wing or airfoil in a fixed position firmly attached. Wings shall be individually approved by the Contest Board. Wing angle may be a minimum of 14 degrees to a maximum of 25 degrees (tolerance of 1degree), measured by putting a straight edge from the leading edge of the wing to the front of the wicker bill.

7.30 Maximum size for wings is 48" front to back X 44" side to side. Right upright 52" long X 18" high, left upright 52" long x 24" high.

7.31 Full underpans are required. These shall extend from just behind the front axle to just ahead of the rear axle. There shall be no holes in the bottom of the underpan, and a liner of oil absorbent material is recommended.

7.32 No fuel additives allowed. Methanol only to be induced into the combustion chamber. Fuel must exhibit all characteristics of pure methanol. Any fuel which develops discoloration after a water test will be deemed illegal. If the car owner requests laboratory testing of a fuel sample failing the water test and the sample is deemed pure methanol, NEMA shall be responsible for the cost of the laboratory test. If the sample is deemed anything other than pure methanol, the car owner requesting the test shall be responsible for the cost of the test. The RaceTek quad-4 engine cars may use ethanol.

7.33 Liquid cooled engines may use any liquid for coolant except Ethylene Glycol or its derivatives.

7.34 Liquid cooled cars must be equipped with a catch tank to receive any liquid pushed out of the radiator. Cars spilling liquid on the track will be given the black flag.

7.35 Rear view mirrors are not allowed.

7.36 Radiator overflow piped into the exhaust is not allowed. Radiators must be mounted in a safe fashion and approved by the NEMA technical inspector. Radiators may not be mounted on the nerf bar of the car and must be affixed solidly to at least one of the main frame rails of the chassis.

7.37 Issue of computers:

- a. No radio or electronic remote adjustment devices will be allowed.
- b. Electronic fuel injection is not allowed. Sealed electromotive based Electronic Fuel Injection (EFI) system will be allowed **only** in conjunction with the following engine, at this time.

Esslinger ST engine with the following technical specifications:

161 cubic inches

9400 rpm limit

Steel billet crank

Steel billet connecting rods

4 Tower CNC ported “Arca” cylinder heads - 31cc combustion chambers

Camshaft - Esslinger part# 2230 steel billet camshaft -655 lift/393.5 duration @ .050 lift

2.020 stainless intake valves

1.600 stainless exhaust valves

Steel valve spring retainers

3 stage dry sump oil pump

Electromotive TECS ECU (Tamper Proof - cannot be modified by anyone outside of the factory, and cannot be accessed by a traditional PC).

Esslinger Engineering will provide each racing series with a proprietary cable and standard ignition program for this engine. Ignition boxes must be programmed & sealed by either Esslinger Engineering or a designated third party for NEMA - Circle Performance, or by the Club tech inspection staff.

Throttle position sensor

Water Temp Sensor

Mechanical fuel pump

All engines will be sealed with NEMA approved seals to prevent tampering with, the Crankshaft, connecting rods, camshaft and cylinder head. All engines will be sealed by either Esslinger Engineering or NEMA's approved third party - Circle Performance, their Designee, with a numbered seal that will be provided to the club. Teams will not tamper with the seals. The

- Penalty for violating this rule will be, a. loss of points, b. a fine, c. suspension, or any combination of a,b,c. All engines will be dyno tested prior to shipping- and will not ever exceed 335 hp. Dyno sheets for each individual engine will be provided to the racing series upon request.
- c. Electronic chassis controls are not allowed.
 - d. Onboard computers are not allowed, except for those engine packages explicitly approved NEMA
 - e. Electronic ignitions will be allowed if approved prior to use; approved systems are:
 - 1. Electromotive Ignition System part # 015-1XIV10 (4 cylinder application).
 - 2. Electromotive Ignition System part # 015-11610 (6 cylinder application).
 - 3. MSD System part # 62XIV and #6420
 - 4. Dyna Ignition system #2000 (cam drive) and #2001 (belt drive),.

Any present or future electronic ignition systems or telltale tachs must be presented to the Officers and Contest Board for approval.

- 1 The Mychron style telltale computer will be legal provided that it only monitors RPM and lap times.
 - 2 Tachometers may have no more than 2 wires and may only record engine rpm.
- g. Radio communication between driver and crew is not allowed.
 - h. All NEMA approved ignition control devices shall be installed and maintained in stock condition (from a NEMA approved OEM manufacturer – i.e.: MSD, Electromotive, etc.) and may not be modified or altered in any way. The ignition system shall have no means of logging and storing data (except for the ignition curve/graph setting). The sole function will be to control the ignition timing and maximum rpm as defined in Rule 7.9(v). * In addition, no devices (mechanical or computerized) will be allowed anywhere on/around or near the competition vehicle that provide any type of traction control benefit and any connections to the ignition control device such as reference sensors or wires that are within the driver's reach shall be made semi permanent. **

The penalty associated with violating the aforementioned rule will be A) loss of points for the event B) loss of points for the season C) fine or suspension to be determined by the NEMA Officials and Contest Board or D) a combination of A, B, and/or C.

If an alternative curve/setting is utilized the ignition timing for that curve/setting must be exactly the same as the primary curve/setting.

At the NEMA technical inspector's discretion any ignition box or settings can be inspected at any time.

* Controlling the ignition timing, as decided by the Officers and Contest Board, shall mean each

ignition box may utilize only 3 points of adjustment – in the MSD ignition box defined as only having 4 total “dots”, including the beginning and ending “dots”, on the MSD Graph View plot. The beginning and ending dots must remain at the stock RPM setting – 800 and 15,000 respectively. The points between the adjustments must be connected by a straight line with no interruptions or spikes between the points.

** Semi permanent shall mean either tape or some form of non-conducting tie strap. All wiring and/or connections in or within the cockpit area must also be completely sealed – (for example, wrapped in tape, enclosed in wire loom, etc.)

7.38 (Reserved for future use)

7.39 On-board fire extinguishers are strongly recommended.

7.40 If during the day’s events, a car flips or rolls over so that it rests on its side or top, it CANNOT be allowed to compete further in that day’s events until inspected and deemed safe to continue by NEMA officials. NOTE: If during the feature event, a car flips or rolls over so that it rests on its side or top, it WILL NOT BE ALLOWED to re-enter the event.

7.41 Airfoils, nose or secondary wings, spoilers or other aerodynamic appendages are not permitted. The Technical Inspectors may have any part or panel removed which in their opinion is not within the spirit or intent of the rule.

- a. Spill plates (vertical panels on hood, nose pieces and other body parts) that restrict airflow over the sides of the body are not allowed.
- b. Ground effect enhancement is not allowed. Any body panels that tend to restrict or increase air flow under the car will not be allowed.
- c. Belly pans are not to be extended beyond the outer edge of the frame rails.

7.42 Any welded titanium suspension parts are prohibited. Welded aluminum Jacobs ladders (Watts linkage) may be utilized. The use of carbon fiber or other composite material as a structural component or suspension component is not allowed. Carbon fiber torque tubes are prohibited. 3/8 inch heims on any part that attaches the front or rear axle assembly to the frame are not permitted. Cockpit side panels must facilitate easy entrance or exit from at least one side of the car, as determined by the tech committee.

7.43 Sail panels between the rear cage upright and brace are allowed. Sail panels may not extend past the structural rear down tube. Regardless of roll cage construction, sail panels may not extend rearward past a vertical line from the most rearward torsion tube.

7.44 A maximum of one cockpit adjustable suspension component will be allowed (including but not

limited to shocks, sway bars, springs, roll bars, pan hard bars, ladders and any adjustments that can affect chassis handling). For the avoidance of doubt, only one cockpit adjuster will be allowed in the cockpit for the aforementioned suspension components (i.e. you cannot have a weight jacker and a shock adjuster knob/cable - even if one of them is disconnected, or two roll bar adjuster handles even if ones of them is disconnected).

7.45 The maximum allowable price for shocks approved for NEMA competition is \$500.00 US. The manufacturer's list price will be used.

7.46 Any vehicle deemed to be not in the "spirit" of the NEMA rulebook and competition guidelines may be suspended from NEMA Competition and/or penalized at the discretion of the Officers and Contest Board.

ARTICLE VIII

FLAGS

8.1 NEMA Officials will use flags as outlined in this Article to provide drivers with information during NEMA Competition Events. At tracks where there are proper lights in the turns they will be use in conjunction with the flags and will have the same meaning. In case of mechanical failure or dispute the flag shall be the official instruction.

8.2 The **GREEN** flag will start the race or indicate a clear course. No race will start until the green flag is displayed. On original starts, cars must hold their position until they pass the starting line.

8.3 The **PASSING** flag (blue with yellow diagonal stripe) will be used to warn a driver that he/she is about to be lapped. Cars that are being lapped are to hold their line and allow the lapping car to proceed. Any car running slow, or deliberately getting in the way of lapping cars will be black-flagged.

8.4 The **BLACK** flag is the consultation or disqualification flag. When the black flag is given it must be obeyed immediately. The DRIVER receiving the black flag must pull off the track within two (2) laps. The black flag will not be given on the last lap.

8.5 The **YELLOW** flag is the caution flag. After receiving the yellow flag, all cars will hold their positions, the outside car giving ground to the inside car, at a reduced speed, closing in to 20 feet apart to await a restart. After a driver has been given a yellow flag, he shall do no passing until he receives the green flag. Any car gaining positions under yellow flag conditions shall be penalized two (2) positions for each position he gained, subject to the scorer's discretion.

8.6 THE RED FLAG MEANS STOP! The red flag is used, if in the opinion of the starter, the race

conditions are unsafe to continue the race. The cars must stop immediately, making sure there is a clear path for the ambulance and the crash vehicles and other service vehicles. When the red flag is dropped, the scoring automatically goes back to the last lap run under the green flag.

8.7 The **WHITE** flag means one (1) lap remaining in the race.

8.8 The **CHECKERED** flag means the race is completed. After the leader has received the checkered flag, the race cannot continue for more than two (2) laps, at which time the red flag must be dropped on the remainder of the field of cars and the cars shall be paid off on the number of laps completed.

ARTICLE IX

COMPETITION STARTS

9.1 All starts are double file starts - the car starting in the first position ("Pole") is the lead car. All cars started in any event must cross the start line two (2) times in order for the first lap to be completed. The only exception shall be for a car that has pulled out for a mechanical failure.

9.2 Cars will be pushed off at the start of the races according to starting positions as determined by the NEMA Officials. If a car stops, it has no more than three laps from the time the last car is pushed off to restart or it is declared out of the NEMA Competition Event. There will be alternate starters in the feature only and only at the handicapper's decision.

9.2 Any car being pushed off for the start of the race shall be given no more than 5 laps to find his spot. Any driver lagging behind to conserve fuel or passing the lap car or pole car shall relinquish his or her position and will be placed in the rear of the field.

9.3 In the event of a drop-out during lining up, the cars in the same line as the drop-out shall move up to fill the empty spot.

9.4 Passing shall be allowed when the green flag drops on all starts and starts shall be off the fourth turn, strictly enforced.

9.5 All qualifying events are inverted starts by handicap or handicapper's discretion. If there will be any change in the qualifying procedure not using the handicap system, all car owners will be notified two weeks in advance.

9.6 Feature events are according to the number of qualifiers, at the handicapper's discretion and after evaluation of the competitors. Qualifiers through the consi will start in the rear of the heat qualifiers by assignment.

9.7 Any car that delays the start of the race or pulls into the pits after the start of hot-laps will start in the rear.

9.8 Prior to the start of a race, scuffing of tires will be allowed only when the racecars are lined up in single file order. The race director will give the ok to all drivers via the one-way radio.

9.9 Two provisional starting spots for cars that did not make it into a transfer spot for the Feature will be the two highest in owner Championship points. For the first three NEMA Competition Events of a season, applicable Championship points shall be those of the preceding year. After the first three NEMA Competition Events of a season are complete, current season owner Championship points shall be used.

ARTICLE X

COMPETITION RE-STARTS

10.1 First lap accidents or spinouts cause a complete re-start and all cars must return to their original starting positions. Any car requiring assistance to restart will start at the rear of the pack.

TO THE REAR OF THE PACK is to the rear of the cars that were running in the leading lap.

10.2 All re-starts shall be double file, except for those in the last five (5) laps of the feature event.

The starter and/or race director shall revert to single file re-starts if, at their discretion, conditions warrant.

10.3 On re-starts subsequent to the first lap, all cars will hold their position until the green flag is dropped.

The re-start positions will be those held in the last completed lap under the green flag, lined up as they passed the starting line. Those cars involved in an accident shall go to the rear of the field.

10.4 If 75% of the race is completed under green flag conditions when the red flag is dropped, it may be declared a competition event. Those cars causing the red flag shall be paid for the last positions of the number of laps they have completed.

10.5 In the case of a spinout or other mishap, which might cause a car to stop on the track during the course of a race, the driver shall make every attempt to remove the car from the track immediately.

10.6 Two Push-Off Rule. A maximum of two (2) push-off/restarts will be allowed for each car in the feature event (not including the initial push-off). These are defined as needing to be pushed off for any reason (other than stopping per order of NEMA Officials). Examples are: A spin out requiring a push-off or a pit stop requiring a push-off. It is the driver's responsibility to refuse to be restarted after the maximum push-offs. The decision of the NEMA Race Officials is final and non-appealable.

10.7 When a race is stopped on account of an accident:

- a. Repair and/or tire changes may be made to any car, whether involved in the accident or not. However, any car making repairs and/or tire changes must be re-started at the rear of the pack.
- b. No repairs of any kind shall be made on the track. The car must return to the pit area or infield, where applicable, to make repairs.
- c. It shall be the responsibility of the driver to re-start in the assigned re-start position.
- d. Repairs shall not be meant to include draining of radiator overflow catch tanks, which may be done at any time the race is stopped.
- e. In the event of several penalized cars, they shall re-start in the same relative order they were running before the penalty. Scorer's decision is final.

10.8 A car stopped for consultation by an official shall be returned to its pre-consultation position. Any car requiring assistance in re-starting for any reason, other than being stopped by a NEMA or a track official must start at the rear of the pack.

10.9 A car may be pushed a maximum of two (2) laps. If the car is not progressing under its own power by this time, it will return to the pit area or infield, whichever is available.

10.10 There shall be no fast laps at any time except during authorized warm-up periods under the direction of the starter and during racing conditions themselves.

10.11 A policy will be in place to determine at each individual event the maximum amount of caution laps to be completed before the red flag is shown to allow for refueling.

ARTICLE XI

POINTS

11.1 A points fund equal to a percentage of the total race gross purse will be established. This points fund will be paid out entirely each year at the end of the season to the top fifteen (15) finishers in the championship point standings of car owners. The value of a point will be determined by dividing the total point fund by the sum of the total number of points earned by the top fifteen (15) finishers.

11.2 Points will be kept for:

- a. Championship
- b. Bonus
- c. Handicap

11.3 Equal CHAMPIONSHIP POINTS will be awarded to all current member car owners and member drivers for each NEMA Competition Event in which they have competed. Championship point accumulations will not be retroactively applied for non-members.

All car owners who pay the Event Entrance Fee and attempt to compete as evidenced by at least one practice lap registered with timing and scoring whether assisted by a push vehicle or not will be awarded Twenty, (20) Appearance Points. The driver of that car will also be awarded Twenty, (20) Appearance Points. A Driver can only be awarded Twenty, (20) Appearance Points per event.

All member car owners and member drivers starting a heat race will be awarded Championship points for that heat race in the following order of finishing 20 to win, 18 for 2nd, 16 for 3rd, 14 for 4th, 12 for 5th, 10 for 6th on back. No championship points will be awarded for semi-feature or consi events. Championship points will include any bonus points received by the member car owners or member drivers. Each owner will be allowed to change a maximum of one chassis per season without affecting car owner or driver Championship points due to catastrophic failure that does not allow the chassis to compete again in the current season, however, a chassis change request must be forwarded in writing to Officers and Contest Board for approval. A NEMA inspection sticker will identify each chassis.

11.4 NEMA Officials may award BONUS points to current member car owners and member drivers as an incentive or to offset an unusual (travel & motel) expenses without altering the purse structure, provided reasonable notice is given to all members. All cars and drivers collecting at least the minimum payoff at the first NEMA Competition Event of the season will automatically receive fifty (50) Bonus Points. All cars and drivers collecting at least the minimum payoff for a two (2) day Competition Event will receive fifty (50) Bonus Points. All car owners will receive an extra 50 bonus points for tracks ½ mile or greater.

11.5 The CHAMPIONSHIP POINT SCHEDULE is as follows:

POSITION	25 LAPS	26-49 LAPS	50+LAP
1	100	125	150
2	88	109	132
3	78	98	117
4	70	88	105
5	62	78	93
POSITION	25-LAPS	26-49 LAPS	50+LAPS
6	56	70	84
7	50	63	75

8	44	55	66
9	40	50	60
10	36	45	54
POSITION	25-LAPS	26-49 LAPS	50+LAPS
11	32	40	48
12	28	35	42
13	24	30	36
14	22	28	33
15	20	25	30
POSITION	25-LAPS	26-49 LAPS	50+LAPS
16	18	23	27
17	16	20	24
18	14	18	21
19	12	15	18
20	10	13	15
POSITION	25-LAPS	26-49 LAPS	50+LAPS
21	8	10	12
22	6	8	9
23	4	5	6
24	2	3	3
25-30	2	2	3
31-on	1	2	3

11.6 HANDICAP points will be kept in a separate register for all Drivers. Drivers will be awarded HANDICAP POINTS from their finishing positions in NEMA Competition Events provided that they have taken the green flag for the feature. Only the previous 25 races will be used for handicap scoring. The HANDICAP POINTS from the last five (5) NEMA Competition Events, which a driver has earned handicap points, will be added together for the drivers current HANDICAP SCORE. A drivers HANDICAP SCORE will be used to set the line-up for Competition Events. A handicap point matrix will be posted, containing every competitor's finishes, the handicap points earned per event and their handicap score. This allows every competitor to know and understand how they have achieved their heat race starting spot prior to that event. The handicapper shall use handicap scores to determine the starting line-up for all feature events, subject to the discretion allowed the Handicapper and Officers and Contest Board by the rules.

Based on car count and number of heats, a predetermined amount of cars will be transferred into the feature via the top finishing positions in their heat race. (If 16 or less cars are in attendance, invert shall be 10; between 17 and 23, invert shall be 12, 24 or over shall be 14). The cars that transferred will occupy the front rows of the feature, according to their handicap score. Cars that do not transfer will fill in the remainder of the feature line-up in the order that they finished their heats. When a driver signs in for an event, their name will be added to the current events matrix, the heat race line-ups will be formulated based upon the entries. The driver with the lowest handicap score will start first in the first qualifying race, and the driver with the second lowest handicap score will start first in the second qualifying race. The qualifying races will then be filled in accordingly.

We will predetermine the amount of cars that we will “transfer” from the qualifying races to the feature event.

Example: we have 20 cars signed in, so we will qualify and transfer 12 cars from the qualifying races utilizing their handicap. Out of those 12 drivers, the one with the lowest accumulated handicap points will start on the pole, the driver with the second lowest accumulated handicap points will start second, and the top 12 spots will be filled in accordingly.

The winner of the previous feature event will start in the last handicapped spot if they have transferred in their qualifying race (in this example it will be 12th).

The remainder of the feature line up (in this example they would be 13th through 22nd) will be transferred “straight up” from their qualifying race finishes.

NOTE: Any feature event winner from the previous six (6) events cannot be posted to start any higher than 6th position in that evening’s current feature event, regardless of their handicap.

Rookies and drivers that have not competed in 2010 or 2011 are considered as having 4 “wins” for their beginning handicap. Drivers that are DQ’d from an event for any reason are credited with 2 wins for that event for handicapping purposes. The best finish in each drivers last feature event will break all “ties”, with the best finishing driver starting behind the other driver(s).

In the event of the cancellation of heat races, qualifying will be determined by the current points standings. Based on the car count, 10, 12, or 14 cars will qualify for the front starting positions. The qualifying field will be inverted with the lowest qualifier on the pole. All rules concerning last winner and past winners apply. The remainder of the field is filled straight up by point standing. New competitors (without points) will start tail.

QUALIFYING BY TIME:

The competition committee may call for a race to utilize batch timing for qualifying. Based on the car count 10, 12, or 14 cars will qualify for the front starting positions. Times recorded during designated practices will be used to establish the qualifying order. Qualifiers can either be fully inverted or the competition committee has the option of calling for an undisclosed number of inverts by draw. The remaining field will be filled straight up by qualifying time. Qualifying by time shall be used when there is a large number (6 or more) of new or visiting drivers.

11.7 Upon arrival at the NEMA Competition Event, all owners and drivers will be required to register with the handicapper or designated person to establish their intent to compete, or forfeit their handicap for that event. Handicap Points for all drivers will be posted prior to qualifying events. To clarify, any owner or driver (or their designee) failing to register/sign-in with the designated official shall also forfeit all points for that event (appearance, bonus, heat and feature).

11.8 In a NEMA Competition Event that is lined up for "Progressive Heats" and Feature, heat points will be given only for the event in which the car qualifies for the Feature, plus any points earned in the feature.

11.9 There will be no points given for match or special races used to fill the show.

11.10 In the event the show is rained out during the rain-check period or during warm-ups, it shall be declared no contest and no points shall be awarded. There will be no pay-off or club sponsored travel allowances.

11.11 Pay-off. Each car owner attempting to compete in a NEMA sanctioned event (not including NEMA Lites) shall receive a minimum of 2% of the gross purse supplied for that event. All such car owners shall receive their earned portion of the purse distribution by NEMA checks within 5 days of NEMA's receipt of payment for the event.

On races that are deemed long travel or 2 day shows, each car owner attempting to compete in a NEMA sanctioned event shall receive a minimum of 2% of the gross purse supplied for that event.

11.12 A driver may drive as many cars as he/she wishes during the events of the day.

However he/she shall receive points only for the car he/she drives at the start of the feature. In the event of a substitution of a driver, the driver will retain the points earned for the Competition Event, regardless of car driven OR in the event of a change of drivers during the feature (red flag conditions), the car will re-start at the rear of the pack and the original driver will get all the points the car earns in the race.

11.13 A qualified car, not driven by the qualifying driver must start at rear of the pack.

11.14 NEMA registered cars and drivers competing in co-sanctioned events, will be awarded championship points for their finishing positions as regards NEMA cars ONLY. Any positions held by members of the co-sanctioning club or other clubs shall be disregarded in determining NEMA's finishing positions.

However, for pay-off purposes, the competitors will receive the monies for the positions designated by the combined, official finish. Should a NEMA registered driver compete in a car with no NEMA affiliation, he/she shall receive NEMA driver points for the position recorded at the official finish.

11.15 All member owners and drivers attempting to compete in a NEMA sanctioned event will receive twenty (20) bonus points as an appearance award.

11.16 Subject to rule 6.6 b, the final starting position of the NEMA feature will be reserved for the winner of the Lites feature. To be eligible the driver must have a minimum of 5 Lites races. If the Lites winner is ineligible or chooses not to compete the spot will be offered to 2nd place finisher, and if the 2nd place finisher is ineligible or chooses not to compete the spot will be offered to the 3rd place finisher. If the 3rd place driver is ineligible or chooses not to compete the spot will remain vacant. The Lite car starting the feature will be allowed one new tire. No points would be awarded but the owner will be paid for their finishing position.

ARTICLE XII

PENALTY GUIDELINES

12.1 Procedure. Any act or omission, which would constitute a violation of any of the NEMA Rules that is brought to the attention of the NEMA Officials, if determined by the NEMA Officials to be severe enough to warrant the imposition of a penalty shall be presented in writing to the NEMA Officials, along with a recommendation for the penalty. The NEMA Officials shall then gather any additional information they deem relevant. After consultation with the Contest Board, and absent any information contradicting the initial report, the NEMA Officials shall impose a penalty. The member shall be notified by certified mail of the violation and penalty, including a brief statement of the facts upon which the NEMA Officials made their decision.

12.2 Any violation of the NEMA Rules is punishable by disqualification, suspension, fines and/or loss of points. While the specific penalty shall be assessed in light of the facts surrounding the violation, NEMA Officials shall use the following guidelines when imposing any penalty, but may assess a greater or lesser penalty, depending on the gravity of the violation and considering whether it is a repeat offense.

- a.** Any member found to have engaged or encouraged others to engage in conduct deemed by the NEMA Officials to be detrimental to midget racing or NEMA generally: Minimum \$50.00 fine and/or suspension from competing and/or loss of Championship points.
- b.** Any member allowing a non-member use of his/her membership card: Minimum \$10.00 fine.

- c. Any member found to have signed a NEMA application, release form or any other official NEMA document for someone else: Minimum \$500.00 fine.
- d. Any member found to have threatened to cause or have caused bodily harm to a NEMA Official: Minimum \$100.00 fine and/or suspension and/or loss of Championship Points.
- e. Any member found to have consumed alcoholic beverages, narcotics or controlled substances during a NEMA Competition Event: SEE APPENDIX A.
- f. Any member found to have engaged in fighting or other form of disorderly conduct during a NEMA Competition Event: Minimum \$100.00 fine and/or suspension.
- g. Any driver failing to obey the flag rules, excluding the black flag: Fine and/or lap penalty.
- h. Any driver failing to obey the black flag: Minimum three (3) race suspension.
- i. Any driver found to have "jumped the start" of any NEMA Competition Event: Loss of two (2) positions for each one (1) gained during the event. For the polesitter, the penalty shall be being put to the rear of the field (after one warning by a authorized NEMA Official).
- j. Any driver failing to remove his/her racecar from the track after being involved in an accident: Three (3) race suspension.
- k. Reserved/Omitted
- l. Any driver found to have taken fast laps during a warm-up period, unless so instructed by the Flagger: Start last in the feature and/or \$25.00 fine.
- m. Any violation of Rule 7.3, 7.4, or 7.29 (mufflers): Warning (1st offense), \$25.00 fine and/or loss of Championship Points (2nd offense), and disqualification from the NEMA Competition Event (3rd offense).
- n. Any car making repairs on the track: Disqualification from the NEMA Competition Event.
- o. Any driver re-starting a NEMA Competition Event out of his/her assigned position: Disqualification from the NEMA Competition Event.
- p. Any car found in violation of technical rules described in article 7: Disqualification from the NEMA Competition Event. Said disqualification will include forfeiture of championship Points for the feature event, car and driver both, and loss of pay-off.
- q. Any driver failing to attend the mandatory drivers meeting required by rule 6.7, if qualified to compete in the feature event, shall start last in the line-up for that event, regardless of previously determined starting position. Dispensation for valid reasons may be applied for by petitioning the NEMA Officials prior to commencement of the meeting.

r. Any car failing to report to the post race technical inspection as required by rule 7.2:

Disqualification from the NEMA Competition Event, car and driver both.

12.3 Fines. All fines associated with any penalty levied by the NEMA Officials shall be paid within thirty (30) days from the date of notification to the member. Failure to pay such fines within thirty (30) days may result in suspension from NEMA Competition Events until paid in full. If such fines are not paid within sixty (60) days, NEMA has the right to withhold the entire amount of the fine from the member's earnings, if applicable. Any fine left unpaid after the final NEMA Competition Event of the season shall be grounds for non-renewal of such individual's membership in the following year.

ARTICLE XIII

PROTESTS

13.1 Technical Protests. If any NEMA member competing in the current event believes that any other NEMA member is gaining an unfair advantage in competition due to a violation of the NEMA Technical Rules, such member may protest such violation to the NEMA Officials. The protest fee shall be \$200.00. The NEMA Officials shall be notified of the protest in writing within 30 minutes of the final technical inspection and the notification shall be accompanied by the protest fee in cash. The Secretary shall notify the protested car owner of the protest. The technical inspector shall inspect the protested car. If the car is in violation of a Technical Rule, the fee will be returned to the protestor and the violating car owner shall be penalized by the NEMA Officials in accordance with Article XII,12.2,p. If no violation is found, the fee is to be retained by the protested car owner. Inspection for illegal use of coolants will not require a protest fee.

13.2 Other Protests. The procedure outline in 13.1 above shall apply to all protests, except the Secretary notification shall be to the protested member, rather than the car owner.

13.3 Non-Protestable Matters. No NEMA member may protest a decision of the NEMA Officials unless specifically provided for in this Rulebook. Review of the decisions of NEMA Officials can be accomplished only through the appeals procedure outlined in Article XIV.

13.4 Protest Review. Any member desiring review of a protest decision may request such a review from the Officers and Contest Board in writing, accompanied by a \$200.00 hearing fee. Affected parties may appear before the Officers and Contest Board and produce any witnesses or evidence they deem relevant to the Officers and Contest Board's review. Such appearances may not be made through council or other representatives. The Officers and Contest Board decisions as to the protest will be final and non-appealable.

The party losing the protest is responsible for reimbursing NEMA for any and all costs incurred by NEMA as a result of the protest. If the protest is overturned, the protest fee will be awarded to the prevailing member.

ARTICLE XIV

APPEALS

14.1 Any member wishing to appeal a decision of the NEMA Officials made pursuant to Article XII, may submit a written notice within ten (10) days of receiving notification of the penalty to the Officers and Contest Board. The notice of appeal must request an appeal hearing in writing, state the member's grounds for appeal in writing, and enclose the \$200.00 hearing fee. All Notices of Appeal must be received by the Officers and Contest Board within the ten (10) day appeal period. All affected members will be given written notice of a hearing date and the opportunity to present witnesses and evidence to the Officers and Contest Board. The Officers and Contest Board shall listen to all witnesses and evidence presented, and vote on the appeal. Any decision must be supported by a majority vote of the Officers and Contest Board.

14.2 Any member wishing to appeal the decision of the Officers and Contest Board pursuant to Rule XIV.1 above, shall submit such a request, in writing, to the Officers and Contest Board within ten (10) days of receiving notification of the Officers and Contest Board's decision. The appeal shall be heard by an independent arbitrator, agreed to by the appealing member and the Officers and Contest Board. The arbitrator may employ any reasonable procedure for the conduct of the hearing and may or may not allow testimony or additional evidence from the parties. The arbitrator must render a decision no later than thirty (30) days after retention by the parties.

Rules for the NEMA Lite Series

The NEMA Lite rules were designed with two principle intents – fair competition and cost effectiveness. These rules will constantly be under review and are subject to change on a regular basis based upon these two intents.

1.0 Any teams found to be going against the spirit or intent of the NEMA Lite rules will be disqualified from the current Competition Event and will be subject to an appearance in front of the NEMA Competition Board.

2.0 The NEMA Lite Series will follow the NEMA Rulebook, EXCEPT for the following modifications stated in this addendum,

2.1 NEMA Lite Weight Rule: All cars competing in a NEMA Lite Competition Event will adhere to the horsepower to weight rule as follows;

- 1) A minimum 1125 lbs, including the driver and driver's gear for cars with a maximum hp of 165.
- 2) A minimum 1200 lbs, including the driver and driver's gear for cars with a maximum hp of 180.
- 3) A minimum 1275 lbs, including the driver and driver's gear for cars with a maximum hp of 195.

All cars must display a weight /hp sticker on the hood.

2.2 NEMA Lite Car Construction Rule: Carbon Fiber and Titanium components of any kind are strongly discouraged from being used but will be allowed on a limited basis as per the discretion of the Technical Inspector.

2.3 NEMA Lite Tire Rule: Each NEMA Lite team will be allowed 2 new tires per event, per vehicle. Any team thought to be or found to be acting outside of the intent of this rule will be penalized via loss of points, prize money, and/or suspension. No new or sticker tire shall be allowed for the Feature Event. If a car owner chooses to use a new or sticker tire, the starting position is forfeited and the car must start at the rear of the field for the Feature event. If a car is found to be violating the rule in warm-ups or heat races they will not be allowed to compete in that event.(warm up or heat race) NOTE; This rule may be modified by the race director if exigent circumstances present themselves that warrant the changes.

2.4 NEMA Lite Wing Angle Rule: Wing angle on quad four powered vehicle not to exceed 20 degrees, all other engines not to exceed 15 degrees. The margin of error is plus or minus one degree. Note: A rookie may be allowed, at the discretion of the competition director, to run more angle for up to 5 races.

2.5 NEMA Lite Wheel Width Rule: "Combo" cars (left or right hand steer (no rack and pinion), chassis kick more than 26.5" from the motor plate): 12" or 10" RR wheel allowed. All other cars: 10" RR wheel allowed. Note: if a Lites competitor's vehicle meets the criteria described in Rule 7.16a then they may apply for a 12" wheel.

2.6 The only approved gas shock for NEMA Lites Competition is the Bilstien Series SG, steel body without schrader valve. **All other gas shocks are prohibited from NEMA Lites Competition.**

3.0 NEMA Lite Engine Rule: The following engines are eligible as described below:

- a. Ford Focus at 122c.i.
- b. Quad Four at 138c.i.
- c. Beginning with the 2015 season the only new Honda engines allowed in NEMA Lite competition will be the sealed USAC Honda HPD engine, They will be allowed the same layover as the focus

motors. The existing 2 Honda K24A1 at 143 c.i. will have an rpm limit of 7,000 and restrictors of a one (1) diameter as determined by the Contest Board.

- d. Honda K24A1 at 143 c.i. and will have restrictors of a diameter as determined by the Contest Board
- e. Ecotec 2.2 litres (134 c.i.) and will have restrictors of a diameter as determined by the Contest Board
- f. For the 2014 season the Lites will have a horsepower rule as follows, there will be three target horsepower's tied to the competition vehicles weight as follows.
 - 1) Maximum hp 165 vehicles must weigh a minimum of 1125 lbs
 - 2) Maximum hp 180 vehicles must weigh a minimum of 1200 lbs
 - 3) Maximum hp 195 vehicles must weigh a minimum of 1275 lbs

*Pursuant to Rule 3.0/E for the purpose of Tech all unsealed focus motors with aftermarket cams will default to 180 hp and will be required to weigh 1200lbs

** Pursuant to Rule 3.0 all engines approved for competition in the NEMA Lites division must comply with rule 3.1.

Each vehicle must display a weight /hp sticker on car.

If the competition director or board feels the vehicle displays a Dominating Performance that is solely based on a horsepower advantage, the car owner may be instructed to bring the competition vehicle in question to a NEMA approved chassis dyno. The competition vehicle will be locked either in the competitors trailer with club padlocks, or transported to the dyno in the club trailer. Upon arrival at the dyno the competitor or nominee will install a gear set bringing the final ratio to within 5 points of 4.93, the vehicle will be fitted with two similar rear tires (left). The car will make 3 consecutive pulls at operating temperature. If the average of the three pulls is above the maximum allowable horsepower the car owner will make whatever changes are necessary to bring the car into compliance, including but not limited to decreasing the hp. or adding weight @6.6bs per additional hp. If the competition car is found to be above the allowable horsepower, the previous finish and points will be vacated. If the competition vehicle is below the horsepower the competitor is not allowed to remove weight but will be deemed legal.

The competition director or board will appoint more than one dyno for the 2014 season and will discuss with the affected member which may be most convenient. The competitor will make arrangements to have the test performed at the earliest possible time. If the car is found to be out of compliance, the fee to the competitor for the test is One Hundred, (\$100.00) dollars. If the car is in compliance, the fee will be paid by NEMA.

If a competitor feels another competitor's car is not in compliance with the allowable horsepower rule, and would like to protest that car and have it Dyno tested, he must present a check to the

competition director within 30 minutes of tech being completed. The protest fee will be Five Hundred, (\$500.00) dollars. If the car is found to be in compliance, the protested car owner will keep Four Hundred, (\$400.00) dollars and One Hundred, (\$100.00) dollars will be used for the dyno fee. If the car is out of compliance the car owner will pay the One Hundred (\$100.00) dollar dyno fee and the protester will receive their Five Hundred, (\$500.00) dollars back. A competitor's protest may only be requested from a car owner in the same race as the car that is being protested.

The contest board and race director will monitor this rule and reserves the right to make any necessary changes to the above written rule throughout the 2014 season to ensure equal and fair competition.

3.1 Lites New Engine Rule: All engines competing in the Lites division will remain predominately stock or comparable. They will all be required to have stock unported cylinder heads and stock internal parts including crankshafts, connecting rods (comparable to stock), and pistons (comparable to stock). Variable cam timing (while running) is not permitted in the lites division. Maximum RPM for all engines shall be 7,300 RPM's.

1. After market camshafts will be allowed.
2. They are also required to be wet sump engines.
3. They are also required to be self-starting.
4. After market cams will be allowed to be degreed at owner's discretion.
5. Cylinder heads will not be allowed to be significantly resurfaced and compression is limited to 1 point over stock.
 - a. Additionally, Ford Focus Engine inclination may be a maximum of thirty degrees from vertical as measured from the vertical centerline of the cylinder bores engine height is 5/8" from flat on bottom of bell housing to bottom of main frame rail.
 - b. Quad 4 maximum of 30 degrees with a crank centerline height of 7 inches from bottom of mainframe rail also there will be no swapping of components between the 2.3(early) and 2.4(late) versions of these motors.
 - c. Honda K24a-1 maximum of 20 degrees with a crank centerline height of 7 inches from bottom of main frame rail and a ten inch wheel.
 - d. Ecotec 2.2 maximum of 20 degrees with a crank centerline height of 7 inches from the bottom of main frame rail and a ten inch wheel.

- e. Quad 4 powered cars have been allowed 7 inches of rear end offset. All other engines are allowed 6.

6. The Lites will utilize a breakout rule. The rule is as follows:

At each Lites competition event, the club will place on the pit board that events break out speed. If during the event a competitor records lap times below the break out speed it is incumbent upon them to make whatever adjustments are necessary to raise their lap times above the breakout speed. If at any time during the competition event, lap times are below the breakout speed, the competition director will take whatever necessary steps to assist the competitor in raising their lap times. Such recommendations will include lowering the wing angle, adjusting off set and/or changing the gear. The competition director shall have full authority to make such recommendations without the consent of the contest board. Should a competitor breakout in the feature event more for more than two events they will be instructed to lower the wing angle by 3 degrees for the next two events, should they still breakout the competition director will make further recommendations.

Note: As stated in the NEMA rulebook, all NEMA Lites cars must run transponders at all times, or will be considered to be in violation of the breakout speed.

In the event the club determines it lacks sufficient data to post a breakout speed it will be so noted on the pit board.

APPENDIX A

POLICY REGARDING USE OF OR POSSESSION OF ILLEGAL DRUGS OR CONTROLLED SUBSTANCES.

- 1. Illegal Drugs Definition:** Illegal drugs are those substances defined and prohibited by Local, State, or Federal laws.
- 2. General Prohibition.** Possession or use of illegal drugs or controlled substances, as define above, is prohibited in any form, by any participant of NEMA, either on the racing facility, or in any area considered to be used in the operation of the racing facility, such as parking lots or leased properties.
- 3. Participant Definition.** A participant is any member taking part in any NEMA Competition Event in any form, including but not restricted to, drivers, car owners, mechanics, crew members, sponsors, track officials, or pit area observers.

4. Violations and Penalties. Notwithstanding Rule 12.2 (e), any participant found to be in possession, under the influence of, impaired by an illegal drug or controlled substance on the racing facility, as defined above, or any person who is arrested by duly-constituted authorities and charged with possession and/or use of illegal drugs or drug substances, or any person who is formally charged by a court of law with illegal drug violations, shall be subject to the following penalties by NEMA:

- a. Suspension from competition and eviction from the speedway property, and denial of further entry to the speedway for a period to be determined by NEMA Officials.
- b. Any participant who is formally charged by a court of law with illegal drug violations, upon notification to NEMA Officials by that agency, shall be suspended from all forms of participation in NEMA until such time as the charges are fully adjudicated through the legal process. Any participant convicted of a formal drug charge by such a process of law will be prohibited from taking part in any NEMA event for a minimum of ten (10) race dates from the time of conviction.

5. Appeals and Hearing. Any participant suspended for violation of these rules may be granted an appeal hearing by the Officers and Contest Board, provided the suspended participant requests such a hearing in writing, within fourteen (XIV) calendar days of the date of suspension. It is the responsibility of the suspended party to make such a request, if a hearing is desired.

6. Reinstatement. A participant suspended for violation of these rules, except in the case of persons charged with selling drugs, may, as the result of a decision reached through the hearing process detailed above, be re-instated, if it is mutually agreed that the participant- at his/her own expense- will produce documentation from a physician licensed within the state, certifying that he/she is drug independent, as a result of random and periodic examinations and urine tests, made at the request of NEMA Officials.

7. Prescribed Drugs. If a participant is using prescription drugs on the advice of a physician, such use must be reported to the President or Vice-President of NEMA prior to the participants entry into any speedway activities. Failure to do so will subject participants to penalties as prescribed above. Anyone using a prescribed drug in a dosage in excess of the prescribed amount will be in violation of this policy.